

# HYDRAULIC CNC PRESS BRAKE

## ADVANCED

Machine Type	Bending Force	Bending Length	Distance Between Columns		Stroke	Daylight	Throat Depth	Table Height	Support Arm
			mm	mm					
			A	B					
1560	60	1600	1300		215	430	310	880	2
2080	80	2100	1700		215	430	310	900	2
26100	100	2600	2200		215	430	310	900	2
3100	100	3100	2600		215	430	310	900	2
3135	135	3100	2600		215	430	310	900	2
3175	175	3100	2600		215	430	310	900	2
3220	220	3100	2600		215	430	310	900	2
3270	270	3100	2600		215	430	310	900	2
37175	175	3700	3200		215	430	310	900	2
37220	220	3700	3200		215	430	310	950	2
4135	135	4100	3600		215	430	310	900	2
4175	175	4100	3600		215	430	310	950	2
4220	220	4100	3600		215	430	310	950	2
4270	270	4100	3600		215	430	310	965	2

HILALSAN has right to change catalogue values and machine technical details without notice. Misprints are not restrictive.

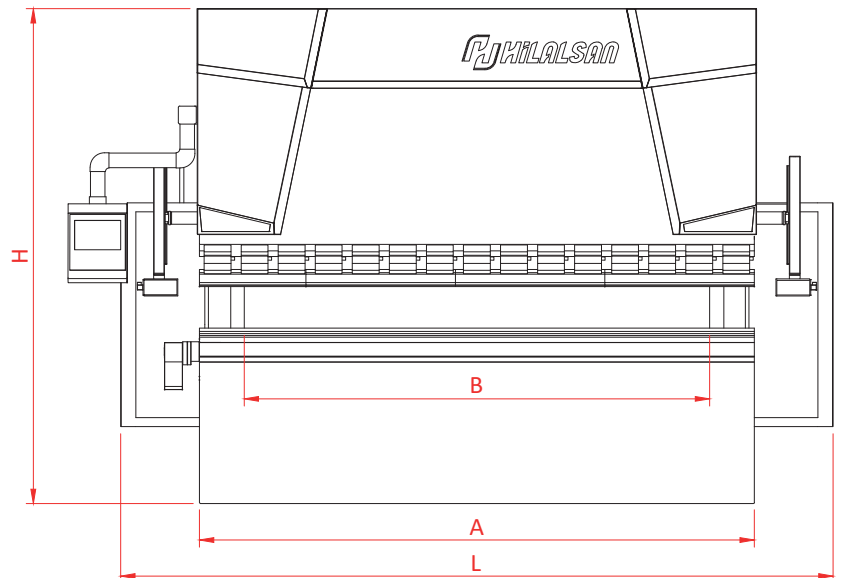

Y Rapid Speed	Y Axis Bend Speed	Y Return Speed	X Axis Speed	Travel in X-axis	Motor Power	Oil Capacity	Length	Width	Height	Approximate Weight
mm/sn.	mm/sn.	mm/sn.	mm/sn.	mm	Kw	Lt	mm L	mm W	mm H	Kg
110	8	110	250	500	5,5	120	2500	1680	2540	3500
110	7	95	250	500	7,5	150	3070	1800	2570	4750
110	9	110	250	500	7,5	150	3500	1855	2600	6000
110	9	110	250	500	7,5	250	4000	1855	2600	6350
110	7	120	250	500	11	250	4000	1875	2620	7200
120	8	110	250	500	15	250	4020	1890	2670	8300
110	9	110	250	500	18,5	250	4040	1860	2735	9750
105	8	100	250	500	22	250	4060	1870	2750	11600
120	8	110	250	500	15	250	4550	2000	2800	10000
110	9	110	250	500	18,5	250	4640	1880	2810	11250
110	7	110	250	500	11	250	5020	1850	2630	9500
120	8	110	250	500	15	250	5020	1860	2740	10500
110	9	110	250	500	18,5	250	5040	1880	2790	12150
100	8	95	250	500	22	250	5060	1900	2850	13600

