

HYPER SERIES

Machine Type	Cutting Length	Cutting Capacity		Number of stroke (No-load)	Cutting Angle		Number of Holddowns	Backgauge course	Backgauge Speed	Motor Power	Oil Capacity	Throat depth
		MS (450N/mm ²)	SS (700 N/mm ²)		Min	Max.						
	mm	mm	mm	1/dak	Degree		Units	mm	mm/sn	Kw	Lt	mm
	A											D
AGM-2006	2080	6	4	13_24	0,3	2	9	1000	100	11	160	150
AGM-2010	2080	10	6	11_19	0,3	2	10	1000	100	22	350	150
AGM-2506	2580	6	4	12_22	0,3	2	11	1000	100	11	160	150
AGM-3006	3080	6	4	11_21	0,3	2	13	1000	100	11	160	150
AGM-3008	3080	8	5	10_18	0,3	2	14	1000	100	18,5	350	150
AGM-3010	3080	10	6	9_17	0,3	2	17	1000	100	22	350	150
AGM-3013	3080	13	8	8_15	0,5	2,3	15	1000	100	30	350	150
AGM-3016	3080	16	10	7_11	0,5	2,5	17	1000	100	30	350	150
AGM-3020	3080	20	13	5_10	0,5	3	18	1000	100	37	550	150
AGM-4006	4080	6	4	9_20	0,3	2	18	1000	100	11	350	150
AGM-4010	4080	10	6	8_16	0,3	2	20	1000	100	22	350	150
AGM-4013	4080	13	8	7_13	0,5	2,3	18	1000	100	30	350	150
AGM-4016	4080	16	10	5_10	0,5	2,5	21	1000	100	30	350	150
AGM-4020	4080	20	13	5_9	0,5	3	21	1000	100	37	550	150
AGM-6006	6080	6	4	8_13	0,5	2	26	1000	100	18,5	350	150
AGM-6010	6080	10	6	7_11	0,5	2	26	1000	100	22	350	150
AGM-6013	6080	13	8	6_11	0,5	2,5	24	1000	100	30	550	150
AGM-6016	6080	16	10	5_9	0,5	2,5	24	1000	100	37	550	150
AGM-6020	6080	20	13	4_7	0,5	3	24	1000	100	37	550	150

HILALSAN has right to change catalogue values and machine technical details without notice. Misprints are not restrictive.

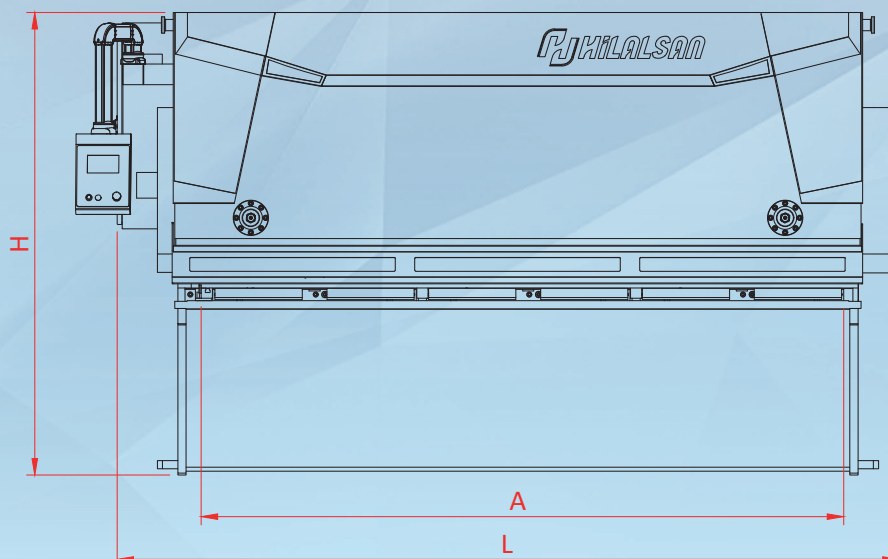

Front Arms	Table height	Length	Width	Total Width	Height	Approximate Weight
Units	mm	mm	mm	mm	mm	mm
	C	L	W	W1	H	Kg
2	800	2800	2120	2770	1900	4650
2	850	2850	2200	2940	2190	7900
3	850	3300	2130	2780	1900	5950
3	850	3850	2130	2780	2200	7250
3	900	3850	2230	2910	2110	8700
3	900	3850	2240	2920	2300	10500
3	900	3900	2260	2960	2350	12850
3	900	3900	2290	3000	2450	16500
3	1000	3950	2320	3050	2650	21500
4	900	4900	2160	2820	2300	10750
4	900	4900	2280	3000	2400	15500
4	900	4900	2310	3020	2550	18400
4	1000	4900	2340	3050	2700	22000
4	1100	5000	2370	3100	2800	27500
6	1000	6900	2200	2860	2550	22500
6	1000	6950	2330	3050	2650	28000
6	1200	6950	2370	3080	2950	35500
6	1200	7000	2410	3120	3150	40500
6	1200	7050	2440	3170	3300	50500

